

**vogelsitze**<sup>®</sup>



**Strada**

**Strada**  
M1



## Strada

### Der Einzelsitz für alle gängigen Minibusse

- Prüfung der Festigkeit der Verankerungspunkte für Sicherheitsgurte gemäß ECE R 16 sowie 76/115/EWG für Fahrzeuge der Klasse M1.
- Prüfung der Sitze, ihrer Verankerungen und Kopfstützen gemäß 74/408/EWG für Fahrzeuge der Klasse M1.
- Zulassung der Isofix Verankerung gemäß ECE R 14 für Fahrzeuge der Klasse M1.

### The Single Seat for all current Mini Buses

- Tests on the stability of the fixing points for the seatbelts in accordance with ECE R 16 and 76/115/EEC for M1 class vehicles.
- Tests on seats, their fixings and headrests in accordance with 74/408/EEC for M1 class vehicles.
- Isofix approved according ECE R 14 for M1 class vehicles.

### Le siège individuel pour tous les minibus du marché

- Contrôle de la résistance des points d'ancrage pour les ceintures de sécurité conformément à la norme ECE R 16 ainsi que 76/115/CEE pour les véhicules de la catégorie M1.
- Contrôle des sièges, de leurs ancrages et des appuie-têtes conformément à 74/408/CEE pour les véhicules de la catégorie M1.
- Isofix ECE R 14 pour les véhicules de la catégorie M1.

### El asiento individual para todos los Minibús corrientes

- Prueba de resistencia de los puntos de anclaje de los cinturones de seguridad según ECE R 16 y 76/115/CEE para vehículos de la clase M1.
- Prueba de los asientos, de sus anclajes y reposacabezas según 74/408/ CEE para vehículos de la clase M1.
- Isofix ECE R 14 para vehículos de la clase M1.



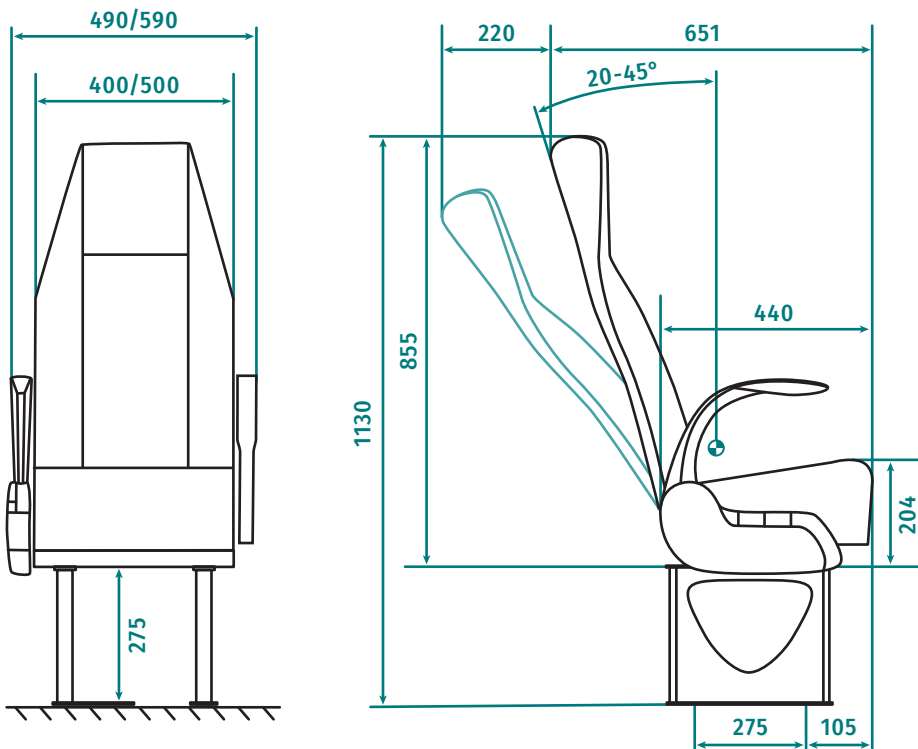

Hochfest  
Fix back rest  
Dossier fixe  
Respaldo fijo



Rückwärtsverstellung  
Seat back reclining mechanism  
Inclinaison du dossier  
Ajuste hacia atras



3 Punktgurtsystem  
3 point belt  
Ceintures 3 points  
Cinturones 3 Puntos



ISOFIX - Kindersitzbefestigung  
ISOFIX - child seat fastening  
ISOFIX - fixation pour siége enfant  
ISOFIX - fijación del asiento del niño

Bogengriff  
Grab handle  
Poignée  
Asidero



Klapptisch  
Tray table  
Tablette  
Mesa



Zeitungsnetz  
Document net  
Porte document  
Revistero



Absenkbare Armlehne  
Fold-down armrest  
Accoudoir escamotable  
Apoyabrazos abatible



Winkelabdeckung  
Seat angle cover  
Cache latéral  
Ángulo de cobertura

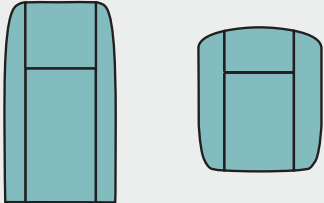
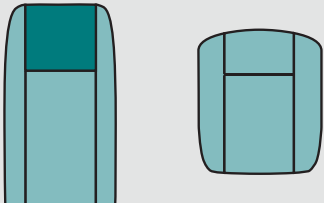
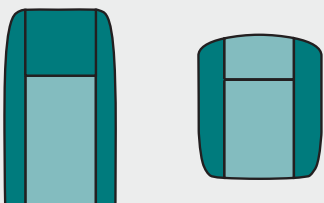
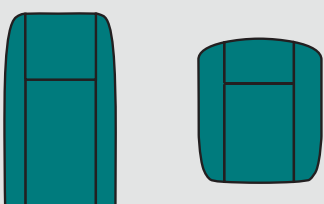

optionale Polsterung | optional upholstery | garnissage optionnel | acolchado opcional

Darstellung graph	Bezeichnung designation	Beschreibung description	Option option
	Standard	Ausführung in Stoff <i>fabric design</i>	<ul style="list-style-type: none"> <li>• Keder <i>pipng</i></li> <li>• Doppelsteppnaht <i>double quilting seam</i></li> </ul>
	Plus	Zusätzlich abgesetzter Kopfeinsatz <i>Additional contrasting headrest insert</i>	<ul style="list-style-type: none"> <li>• Ambassador: hochwertige Doppelpolsterung <i>Additional Ambassador upholstery</i></li> </ul>
	Prestige	Zusätzlich abgesetzter Kopfeinsatz und Seitenteile <i>Additional contrasting headrest insert and side parts</i>	<ul style="list-style-type: none"> <li>• Deluxe: zusätzlich 10 mm Schaumpolsterung <i>Additional Deluxe 10 mm upholstery</i></li> </ul>
	Executive	Ausführung in Vollleder <i>leather design</i>	

Kontakt | contact | contacter | contacto

## Vogelsitze GmbH

Kleinsteinbacher Straße 44  
D-76228 Karlsruhe  
Germany

Phone | Telefon: +49 721 4702 0  
Fax | Telefax: +49 721 4702 2500  
E-Mail: info@vogelsitze.com