

*vogelsitze*<sup>®</sup>



LS20

LS20  
Coach

## LS20

### Qualität als Ergebnis von Erfahrung und Know-how

Der Klassiker für komfortable Reisen. In der LS20-Baureihe sind Erfahrung und modernste Technik intelligent miteinander kombiniert, um die hohen Anforderungen an Komfort und Qualität zu erfüllen. Eine Vielfalt an Stoffen und Leder erleichtert die optimale Abstimmung im Fahrgastraum.

### Quality through experience and know-how

The classic choice for luxury traveling. The LS20 series, an intelligent combination of experience and state-of-the-art technology, meets the most demanding comfort and quality requirements. Wide choice of textiles and leather for an attractive passenger compartment.

### Expérience et savoir-faire au service de la qualité

La version classique pour des voyages tout confort. Dans la gamme de fabrication LS20, l'expérience et la technique la plus moderne sont combinées de manière intelligente, afin de satisfaire aux grandes exigences en matière de confort et de qualité. Un grand choix de tissus et de cuirs facilite une harmonisation optimale dans l'espace passagers.

### Calidad resultante de nuestra experiencia y know-how

El confort de viajar. La serie LS20 combina una larga experiencia con una tecnología de vanguardia, que permite satisfacer las más altas exigencias en materia de confort y calidad. Múltiples variantes en tapicerías y pieles facilitan la óptima coordinación en el habitáculo.



SAFER



CLEANER



LIGHTER



SMARTER

### Core-Struktur – Die leichtere Lösung

#### Reise-/Überlandbusse

#### Gewichtersparnis im Premium- und Standardsegment

- weniger CO<sub>2</sub>-Ausstoß
- geringerer Kraftstoffverbrauch

#### Vereinheitlichte Struktur für alle Reise- und Überlandbus-Sitze

- nur eine benötigte Fahrzeughomologation für sechs verschiedene Sitztypen nach ECE R 14

#### Innovation

- optimierter Sitzkomfort durch neue ergonomische Ausformung

#### optional:

- Gurthöhenverstellung mit Rastfunktion
- Vorrichtungen zur Nutzung Ihrer mobilen Medien

### Core-Structure – The lighter solution

#### Coach/Intercity Seats

#### Weight reduction in the premium and standard segments

- reduced CO<sub>2</sub> emission
- lower fuel consumption > fuel cost savings

#### Common structure for all coach and intercity seats

- only one homologation/bus needed for all six different seat types according to ECE R 14

#### Innovation

- optimized seating comfort due to a new ergonomical shape

#### optional:

- seat belt high adjuster with snap mechanism
- ready for your mobile connectivity

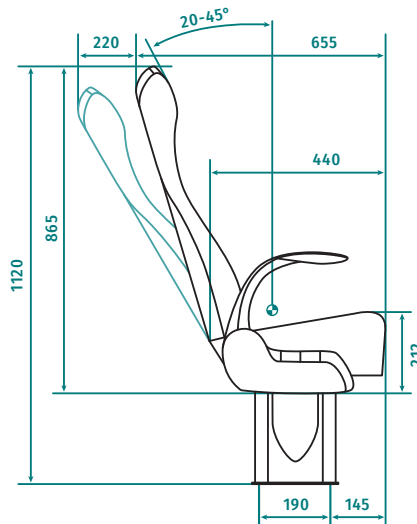
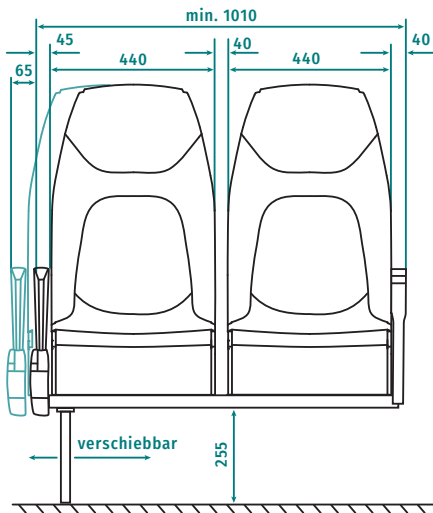

Hochfest  
Fix back rest  
Dossier fixe  
Respaldo fijo



Rückwärtsverstellung  
Seat back reclining mechanism  
Inclinaison du dossier  
Ajuste hacia atras



Seitwärtsverstellung  
Sideway movement  
Décalage latéral  
Ajuste lateral



ISOFIX - Kindersitzbefestigung  
ISOFIX - child seat fastening  
ISOFIX - fixation pour siège enfant  
ISOFIX - fijación del asiento del niño



2 Punkt- u. 3 Punktgurtsystem  
2 point and 3 point belt  
Ceintures 2 et 3 points  
Cinturones de 2 y 3 Puntos



USB-Anschluss  
USB port  
Port USB  
Puerto USB



Steckdose 220V  
Power outlet 220V  
Socle 220V  
Enchufe 220V



F-Variante  
F-variation  
Variante F  
Variante F



USB-Anschluss  
USB port  
Port USB  
Puerto USB



Bogengriff  
Grab handle  
Poignée  
Asidero

Wurzelnußbaum-Dekor  
WNB (rootwood)  
WNB (bois)  
WNB (madera)



Carbon-Dekor  
Carbon  
Carbone  
Carbono



Perlmausgrau (ähn. RAL 7048)  
Pearl mouse grey (sim. RAL 7048)  
Gris perlé (sim. RAL 7048)  
Gris perla (sim. RAL 7048)



Armauflage  
Decor for armrest  
Décor de bras  
Decoraciones de brazos

Pompadour-Tasche  
Bag  
Aumônière  
Bolsillo Pompadour



Zeitungsnetz  
Document net  
Porte document  
Revistero



Absenkbare Armlehne  
Fold-down armrest  
Accoudoir escamotable  
Apoyabrazos abatible



Klapptisch  
Tray table  
Tablette  
Mesa

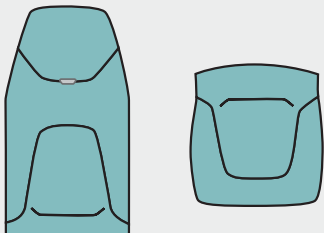
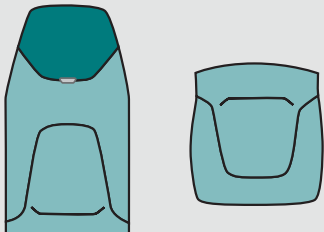
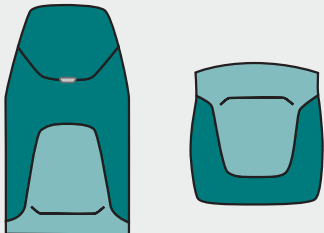
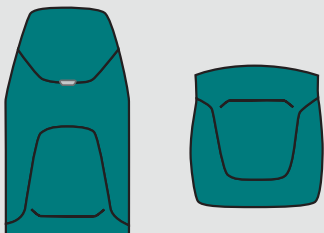

optionale Polsterung | optional upholstery | garnissage optionnel | acolchado opcional

Darstellung graph	Bezeichnung designation	Beschreibung description	Option option
	Standard	Ausführung in Stoff <i>fabric design</i>	<ul style="list-style-type: none"> <li>• Keder <i>pipng</i></li> </ul>
	Plus	Zusätzlich abgesetzter Kopfeinsatz <i>Additional contrasting headrest insert</i>	<ul style="list-style-type: none"> <li>• Doppelsteppnaht <i>double quilting seam</i></li> </ul>
	Prestige	Zusätzlich abgesetzter Kopfeinsatz und Seitenteile <i>Additional contrasting headrest insert and side parts</i>	<ul style="list-style-type: none"> <li>• Deluxe: zusätzlich 10 mm Schaumpolsterung <i>Additional Deluxe 10 mm upholstery</i></li> </ul>
	Executive	Ausführung in Vollleder <i>leather design</i>	

Kontakt | contact | contacter | contacto

## Vogelsitze GmbH

Kleinsteinbacher Straße 44  
D-76228 Karlsruhe  
Germany

Phone | Telefon: +49 721 4702 0  
Fax | Telefax: +49 721 4702 2500  
E-Mail: info@vogelsitze.com